

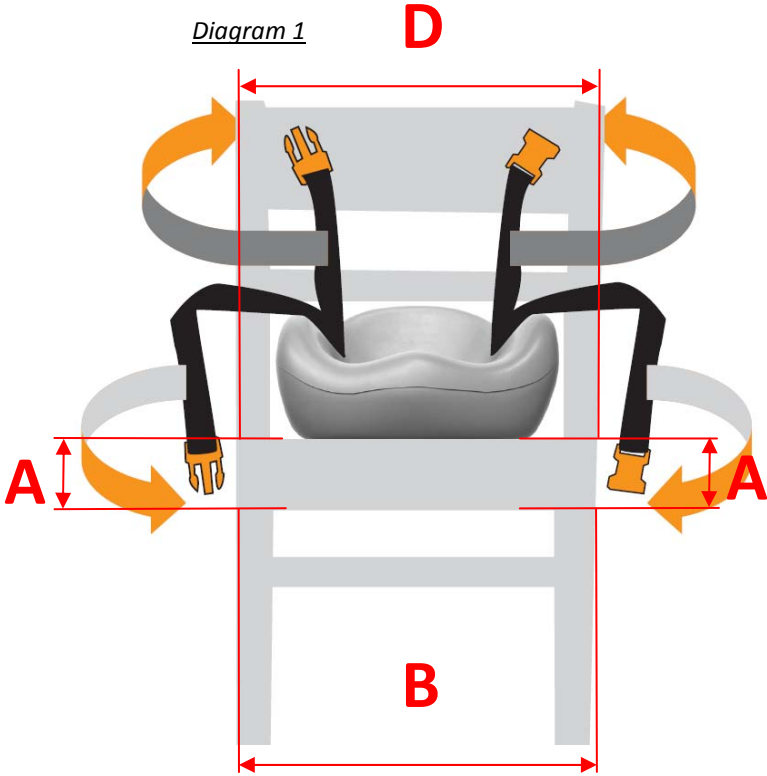

Café Booster Strap Length measurement instruction.



Chair Seat Measurement Instructions:

1. Measure all locations approximately 5" from the seat back. (As show in Diagram 2)
2. Measure the seat thickness (Either location A) and multiply by 2.
3. Measure the distance width of the chair seat. (Location B)
4. Add the three numbers together. (Seat Thickness x 2) + Seat Width

*If the number is **between 15" and 26.5"** the included straps will work.*

*If the number is **less than 15" or more than 26.5"**, please call our office for strap options. 800-994-2416.*

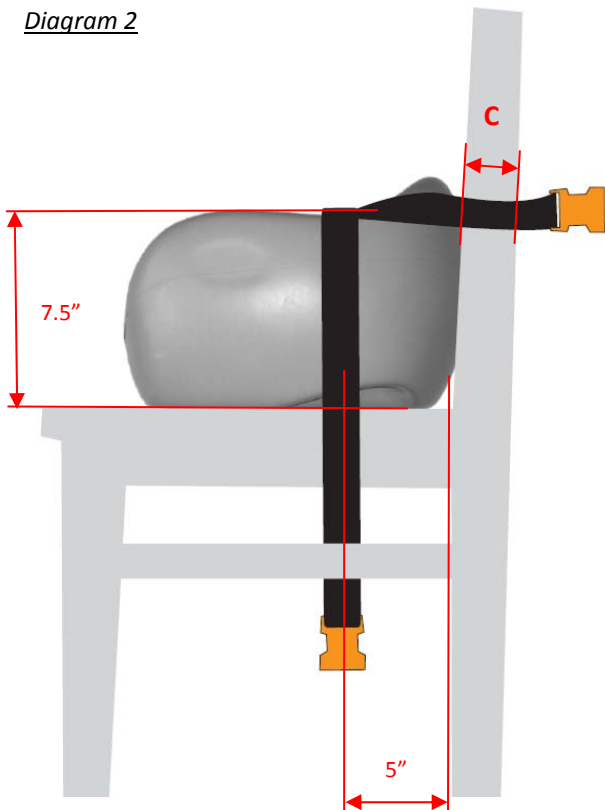

Chair Back Measurement Instructions:

1. Measure all distances 7.5" from the seat plate. (As shown in diagram 2)
2. Measure the Chair Back Thickness (Location C) and multiply by 2.
3. Measure the Chair back width (Location D).
4. Add three numbers together (Seat Back Thickness x 2) + Chair back width.

*If the number is **between 13" and 21"** the included straps will work.*

*If the number is **less than 13" or more than 21"**, please call our office for strap options. 800-994-2416.*